

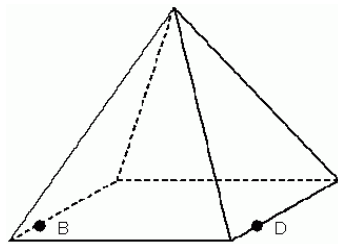



1. Find the equation of the circle with radius 9 and its center at the origin.
 - A. $x^2 + y^2 = 1$
 - B. $x^2 + y^2 = 9$
 - C. $x^2 + y^2 = 18$
 - D. $x^2 + y^2 = 81$

2. The equation of a circle is $(x - 7)^2 + (y + 5)^2 = 36$. What is the location of the center of the circle?
 - A. $(-7, -5)$
 - B. $(-7, 5)$
 - C. $(7, -5)$
 - D. $(7, 5)$

3. Identify a three-dimensional shape with two parallel and identical polygonal bases connected by a lateral surface area.
 - A. Pyramid
 - B. Cone
 - C. Prism
 - D. Cylinder

4. Given the square pyramid pictured here, if you sliced the pyramid vertically through points *B* and *D*, the shape of the cross section is which of the following?



- A. 
- B. 
- C. 
- D. 

5. Find the measure of $\angle 1$ in $\odot O$.

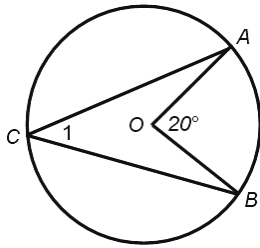

- A. 20°
- B. 10°
- C. 60°
- D. 40°

6. A rancher increased the number of horses he owned for each of the past five years. The number of horses he owned each year is listed in the table. Using the pattern, how many horses will the rancher own in year 6?

<i>Year</i>	<i>Horse</i>
1	3
2	6
3	11
4	18
5	27
6	

- A. 13 horses
- B. 36 horses
- C. 38 horses
- D. 40 horses

7. R is the midpoint of the segment MN. M is located at $(4, -3)$ and R is located at $(6, 1)$. What is the location of N?

- A. $(3, 5)$
- B. $(5, 2)$
- C. $(5, 8)$
- D. $(8, 5)$

8. The ratio of surface areas of two similar cubes is 25 : 64. Find the volume of the larger cube if the volume of the smaller cube is 1000 in^3 .

- A. 1600 in^3
- B. 2560 in^3
- C. 4096 in^3
- D. 6400 in^3

9. What is the surface area of the rectangular prism shown below?

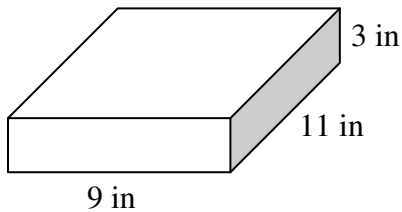

- A. 159 in^2
 - B. 219 in^2
 - C. 297 in^2
 - D. 318 in^2
10. What is the volume of a cone with a radius of 5 m and a height of 6 m? *Round your answer to the nearest hundredth.*

- A. 471.24 m^3
- B. 157.08 m^3
- C. 50.00 m^3
- D. 26.18 m^3

11. Jeremy has a box with the dimensions given below. He wants to place candies in the box that are 1 cubic cm in size. How many candies can he fit in the box?

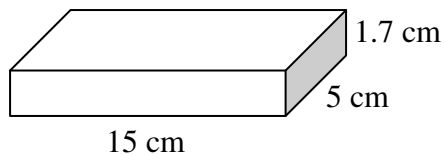

- A. 21 candies
- B. 75 candies
- C. 127 candies
- D. 128 candies

12. What is the cross section of a cone formed by the intersection of a plane parallel to the base of the cone?

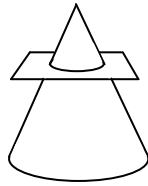

- A. circle
- B. ellipse
- C. parabola
- D. triangle

13. In the diagram of $\odot O$, $m\angle JOK = 72^\circ$ and $OJ = 5$ cm. What is the exact length of \widehat{JK} ?

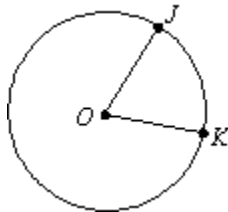

- A. 2π cm
- B. 5π cm
- C. 10π cm
- D. 25π cm

14. In the diagram of $\odot O$, $m\angle JOK = 60^\circ$ and $OJ = 6$ in. What is the exact area of the shaded region?

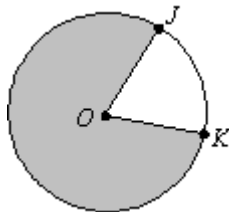

- A. 36π in²
- B. 30π in²
- C. 6π in²
- D. $\frac{\pi}{6}$ in²

15. In the diagram of $\odot P$, $m\widehat{RS}$ is 80° , and $RS = RT$. What is $m\angle SRT$?

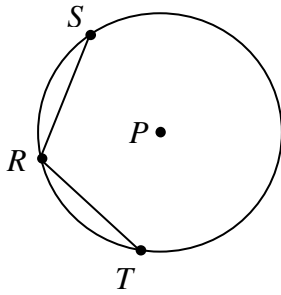

- A. 80°
- B. 100°
- C. 160°
- D. 200°

16. In the diagram of $\odot P$, $m\angle SRT = 66^\circ$. What is $m\angle SPT$?

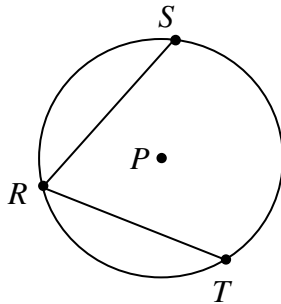

- A. 33°
- B. 66°
- C. 106°
- D. 132°

17. In a circle, what is the relationship between the diameter, circumference, and π ?

- A. $C\pi = d$
- B. $Cd = \pi$
- C. $\frac{C}{d} = \pi$
- D. $\frac{d}{C} = \pi$

18. What figure is formed by the intersection of the cone in the attached figure and a plane containing line h ?

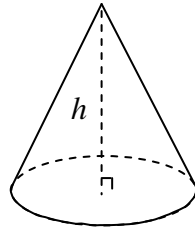

- A. circle
- B. ellipse
- C. square
- D. triangle

19. What is the equation of the circle shown below?

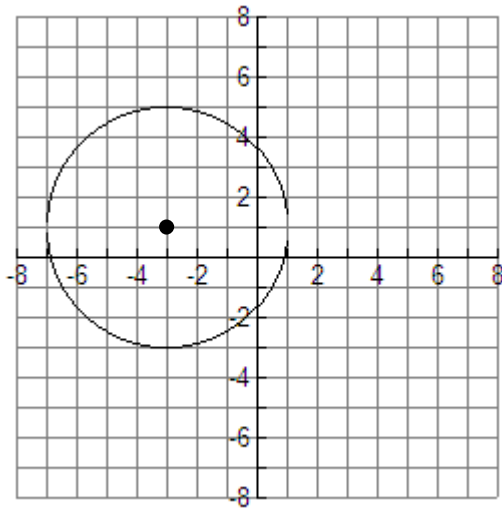

- A. $(x+3)^2 + (y-1)^2 = 16$
- B. $(x-3)^2 + (y+1)^2 = 4$
- C. $(x+3)^2 + (y-1)^2 = 4$
- D. $(x-3)^2 + (y+1)^2 = 16$

20. In $\odot G$, what is \overline{HI} ?

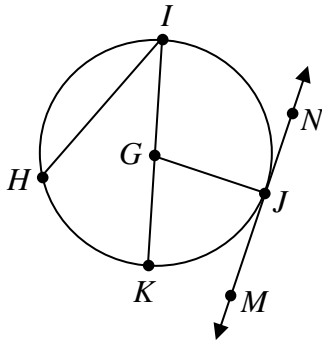

- A. a tangent
- B. a secant
- C. a diameter
- D. a chord

21. What is the value of x in the diagram shown below?

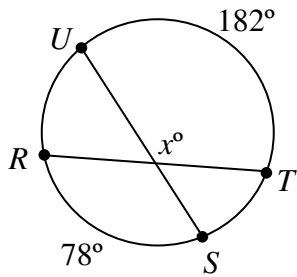

- A. 52°
- B. 104°
- C. 125°
- D. 130°

22. At Mario's Pizza Place, every pizza is cut into 8 congruent slices. Each slice has an area of $8\pi \text{ in}^2$. What is the radius of the pizza?

- A. 4 inches
- B. 8 inches
- C. 12 inches
- D. 16 inches

23. P is the center of the circle. If C is the midpoint of \overline{BA} and $CA = 3$, what is XY ?

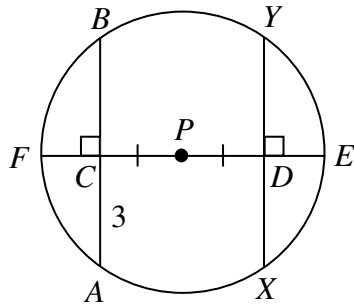

- A. 3
- B. 6
- C. 9
- D. 12

24. Which of the following can be folded to form the prism below?

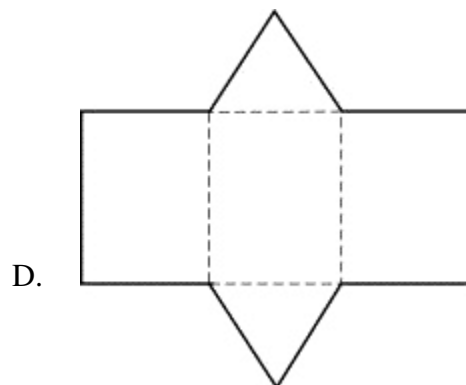
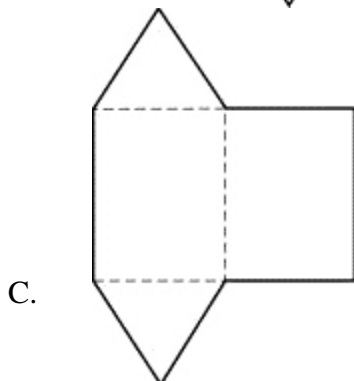
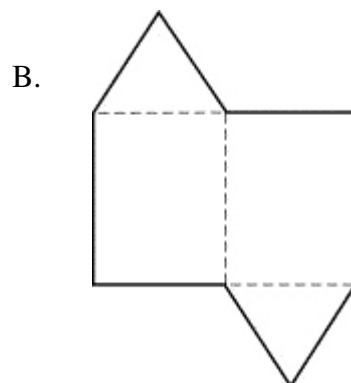
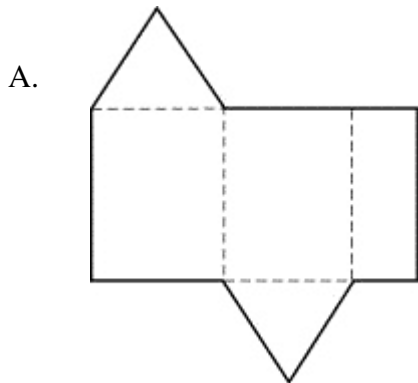
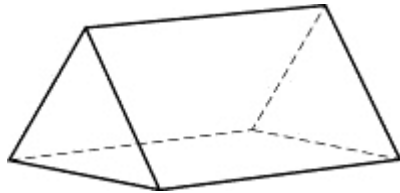

25. Identify the dotted line.

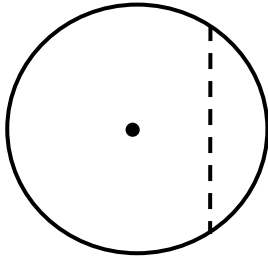

- A. Center Point
- B. Chord
- C. Circumference
- D. Radius

26. In Circle B, identify the part of the circle between A and C.

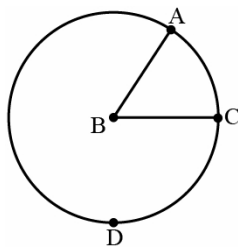

- A. Arc AC
- B. Chord AC
- C. Circumference AC
- D. Radius AC

27. If a plane intersects a cylinder parallel to the base, the intersection will form which of the following geometric shapes?

- A. circle
- B. rectangle
- C. square
- D. triangle

28. What is the area of the region shown below?

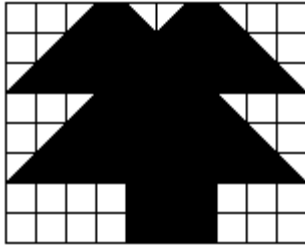

- A. 40 units²
- B. 47 units²
- C. 50 units²
- D. 80 units²

29. Which of the following equations represents a line parallel to the line given by $y = 5x + 9$?

- A. $y = 5x + 1$
- B. $y = 3x + 9$
- C. $y = -\frac{1}{5}x + 9$
- D. $y = -5x + 4$

30. A train travels up a hill at a 12° angle. The train rises 150 feet from the bottom to the top of the hill. Approximately how long is the track?

- A. 31 ft
- B. 153 ft
- C. 705 ft
- D. 721 ft

31. Find the number of vertices, faces, and edges for the figure shown here.

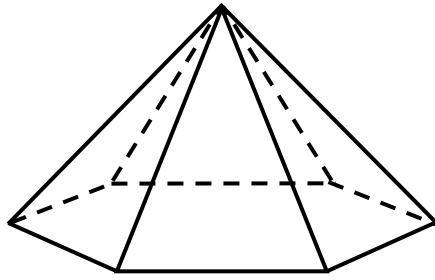

- A. 6 vertices, 7 faces, 12 edges
- B. 7 vertices, 7 faces, 12 edges
- C. 8 vertices, 8 faces, 13 edges
- D. 12 vertices, 7 faces, 7 edges

32. Find the area of the regular pentagon with an apothem equal to 8.2 m. $\left(A = \frac{1}{2} P a \right)$

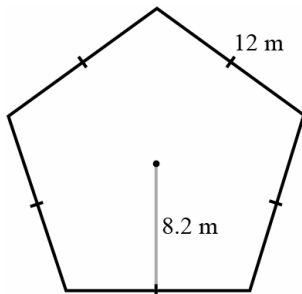

- A. 240 m²
- B. 246 m²
- C. 369 m²
- D. 492 m²

33. Which postulate or theorem can be used to prove $\triangle ABD \cong \triangle CDB$?

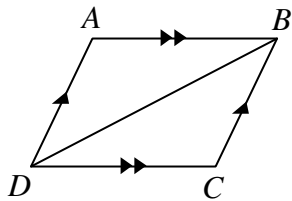

- A. SAS
- B. SSS
- C. ASA
- D. AAS

34. Which of the following statements is equivalent to "If John gets paid, then it's Tuesday"?

- A. John gets paid every Tuesday.
- B. John doesn't get paid, so it's not Tuesday.
- C. It's not Tuesday, so John doesn't get paid.
- D. Today is Monday. Maybe John will get paid tomorrow.

35. In $\odot C$, $m\angle ACB = x^\circ$. What is the $m\angle ADB$?

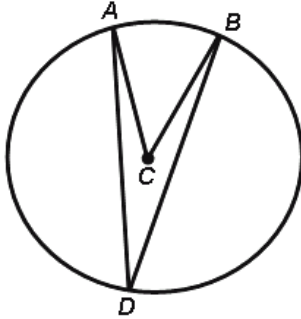

- A. $\left(\frac{1}{4}x\right)^\circ$
- B. $\left(\frac{1}{2}x\right)^\circ$
- C. $(x)^\circ$
- D. $(2x)^\circ$